

AWS Series Quasi-wavelength Laser



Key Features

- Power stability $\pm 2\%$ @ 4h
- With PC control function
- Multiple wavelength options
- Multi-mode fiber available
- Fiber collimator available

Applications

- Fluorescence spectrometer
- Particle size analyzer
- Flow cytometer
- Confocal microscopy

Technical Specifications

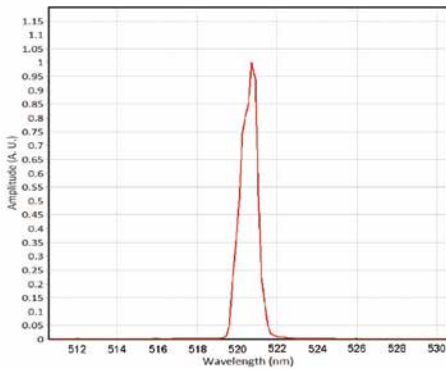

520nm spectrum

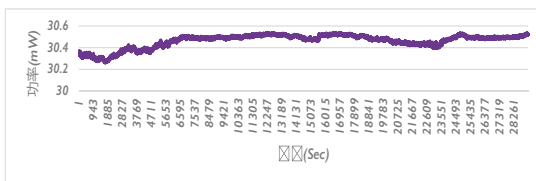

520nm power stability @8h

Optical Parameters					
Center Wavelength (nm)	405	450	520	638	650
Wavelength Tolerance (nm)	± 5	± 10	± 10	± 10	± 10
Output Power (mW)	100	100	100	100	100
Linewidth (nm)	<math>< 3</math>				
Output Fiber	105/0.22				
Connector	FC/PC, FC/APC				
Power Stability	$\pm 2\%$ @ 4h Typ.				
System Parameters					
Adjustability % Full Power	0~100%				
Warm up Time (min)	15				
Modulation Input	Analog signal 100Hz				
Control Interface	USB, BNC				
Supply Voltage	+5VDC				
Power Consumption (W)	<math>< 7</math>				
Storage Humidity	0~70% RH				
Storage Temperature ($^{\circ}\text{C}$)	-10~60				
Operating Temperature ($^{\circ}\text{C}$)	10~35				
Weight (kg)	<math>< 1.2</math>				
Dimensions (mm)	168 \times 88 \times 140				

Part Numbering Schema

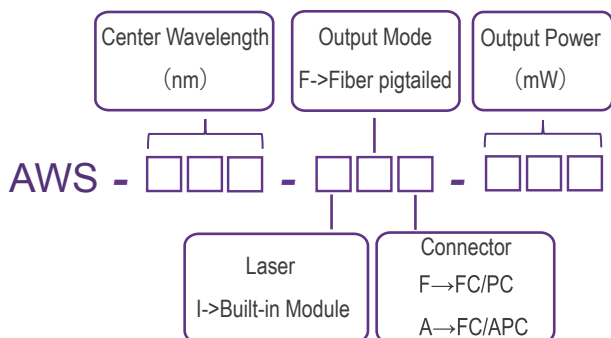

Ordering Information

Wavelength (nm)	Output Power (mW)	Part Number	Connector
405	100	AWS-405-IF(F)-100	FC/PC
	100	AWS-405-IF(A)-100	FC/APC
450	100	AWS-450-IF(F)-100	FC/PC
	100	AWS-450-IF(A)-100	FC/APC
520	100	AWS-520-IF(F)-100	FC/PC
	100	AWS-520-IF(A)-100	FC/APC
638	100	AWS-638-IF(F)-100	FC/PC
	100	AWS-638-IF(A)-100	FC/APC
650	100	AWS-650-IF(F)-100	FC/PC
	100	AWS-650-IF(A)-100	FC/APC

Mechanical Drawings (mm)

