

# CARBIDE

## Femtosecond Lasers for Industry and Science



### FEATURES

- < 290 fs – 10 ps tunable pulse duration
- > 400 μJ pulse energies
- > 40 W output power
- 60 – 2000 kHz tunable base repetition rate
- Includes pulse picker for pulse-on-demand operation
- Rugged, industrial grade mechanical design
- Air or water cooling
- Automated harmonics generators (515 nm, 343 nm, 257 nm)
- Scientific interface enhancing system flexibility

CARBIDE femtosecond laser features an output power of >40 W at 1028 nm wavelength. The laser emits pure pulses with ASE background of  $<10^{-9}$  and recently updated max energy specifications without any compromises to the beam quality, industrial grade reliability and beam stability regardless of the environmental conditions. Continuously tunable repetition rate in a range of 50 kHz to 2 MHz is combined with an in built Pulse Picker for output pulse timing and full scale energy

control with <10 microsecond response time, enabling arbitrary shaping of the emission. Pulse duration can be tuned in a range of 290 fs – 10 ps. Excellent power stability of <0.5 % RMS is standard. The laser output can be split into several burst pulses of pico- and nano- separation while having the ability to modify the burst envelope. Harmonic generator options permits femtosecond applications at different wavelengths. The parameters are entirely software adjustable.

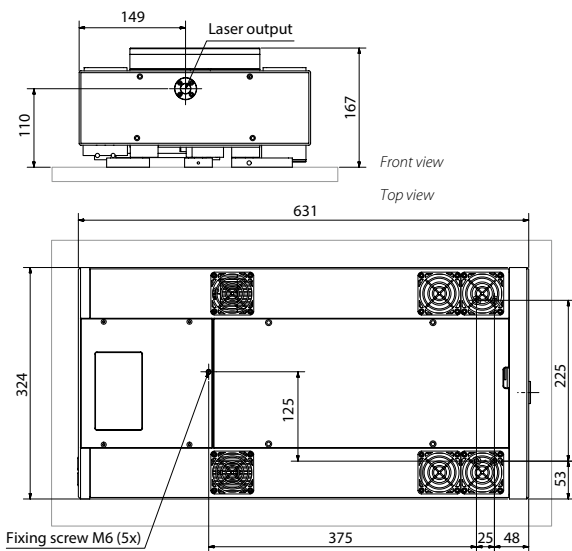

Outline drawing of air-cooled CARBIDE

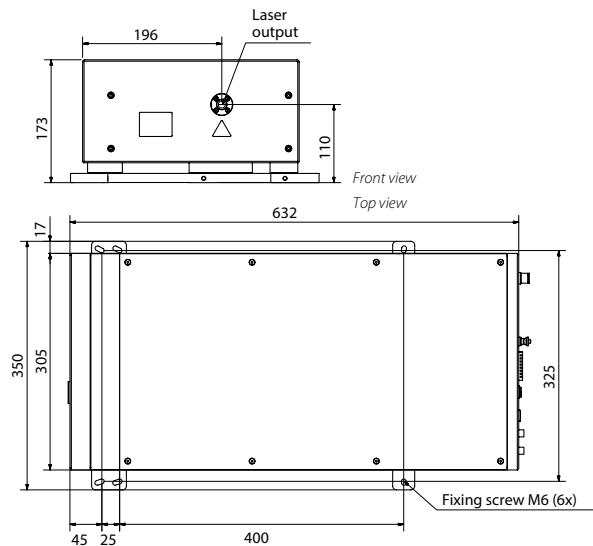

Outline drawing of water-cooled CARBIDE

**SPECIFICATIONS**

Product name	CB5-06		CB3-40-200	CB3-40-400
<b>OUTPUT CHARACTERISTICS</b>				
Cooling method	Air-cooled <sup>1)</sup>		Water-cooled	
Max. average power	> 6 W	> 5 W	> 40 W	
Pulse duration (assuming Gaussian pulse shape)	< 290 fs			
Pulse duration adjustment range	290 fs – 10 ps			
Max. pulse energy	> 100 µJ	> 80 µJ	> 200 µJ	> 400 µJ
Base repetition rate <sup>2)</sup>	60 – 1000 kHz		200 – 2000 kHz	100 – 2000 kHz
Pulse selection	Single-shot, any base repetition rate division			
Centre wavelength <sup>3)</sup>	1028 ± 5 nm			
Output pulse-to-pulse stability	< 0.5 % rms over 24 hours <sup>4)</sup>			
Output power stability	< 0.5 % rms over 100 hours			
Beam quality	TEM <sub>00</sub> ; M <sup>2</sup> < 1.2			
Pulse picker	included	included, enhanced contrast AOM <sup>5)</sup>	FEC <sup>6)</sup>	
Pulse picker leakage	< 2 %	< 0.1 %	< 0.5 %	
Beam pointing stability	< 20 µrad/°C			
BiBurst mode	-		Tunable GHz and MHz burst with burst-in-burst capability	
<b>ENVIRONMENTAL &amp; UTILITY REQUIREMENTS</b>				
Operating temperature	17 – 27 °C (62 – 80 °F)		15 – 30 °C (59 – 86 °F)	
Relative humidity	< 80 % (non condensing)			
Electric	110 – 220 VAC, 50 – 60 Hz			
Power consumption	< 200 W		1.5 kW	
<b>DIMENSIONS</b>				
Laser head	631 (L) × 324 (W) × 167 (H) mm		632 (L) × 305 (W) × 173 (H) mm	
Power supply	220 (L) × 95 (W) × 45 (H) mm		280 (L) × 144 (W) × 49 (H) mm	
Chiller	-		590 (L) × 484 (W) × 267 (H) mm	

<sup>1)</sup> Water-cooled version available on request.

<sup>2)</sup> Lower repetition rates are available by controlling pulse picker.

<sup>3)</sup> 2nd (515 nm) and 3rd (343 nm) harmonic output also available.

<sup>4)</sup> Under stable environmental conditions.

<sup>5)</sup> Provides fast amplitude control of output pulse train.

<sup>6)</sup> Provides fast energy control; external analog control input available.

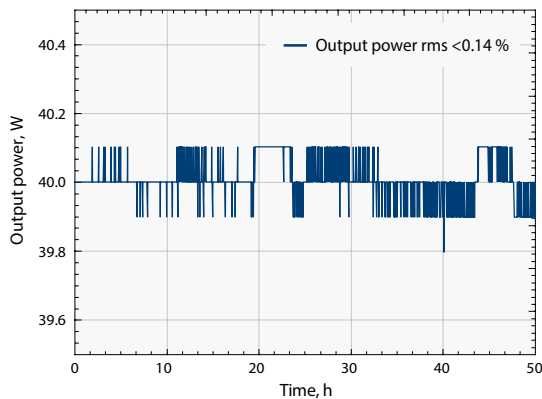

Long term power stability (water-cooled version)

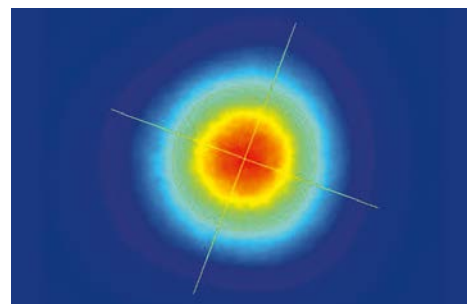

Typical CARBIDE beam profile (water-cooled version)

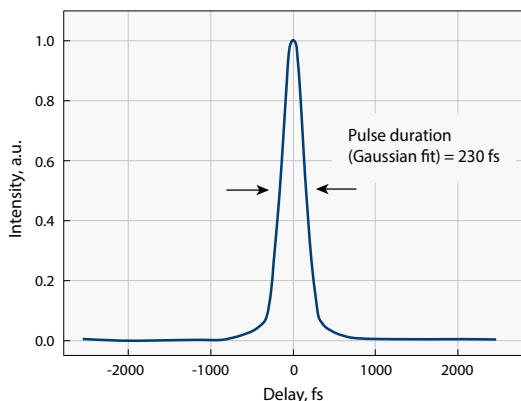

Pulse duration of CARBIDE (water-cooled version)

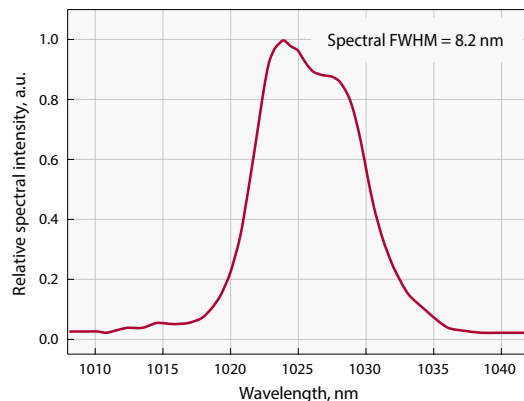

Spectrum of CARBIDE (water-cooled version)

**AIR-COOLED CARBIDE STABILITY MEASUREMENTS**

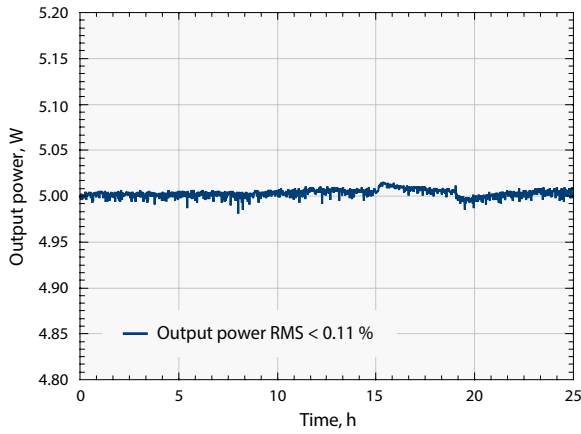

Output power under harsh environment conditions (air-cooled version)

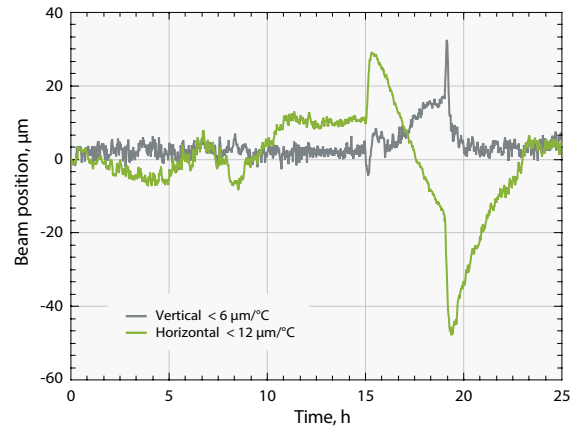

Beam position under harsh environment conditions (air-cooled version)

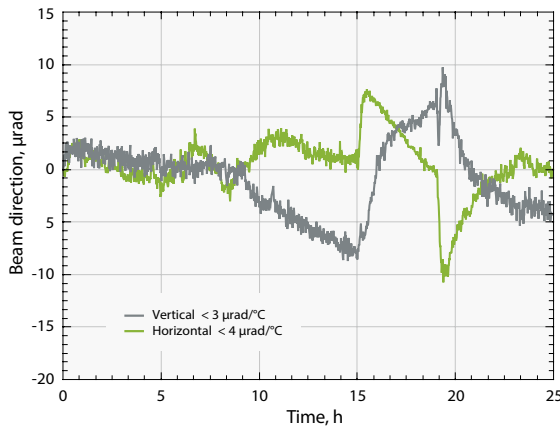

Beam direction under harsh environment conditions (air-cooled version)

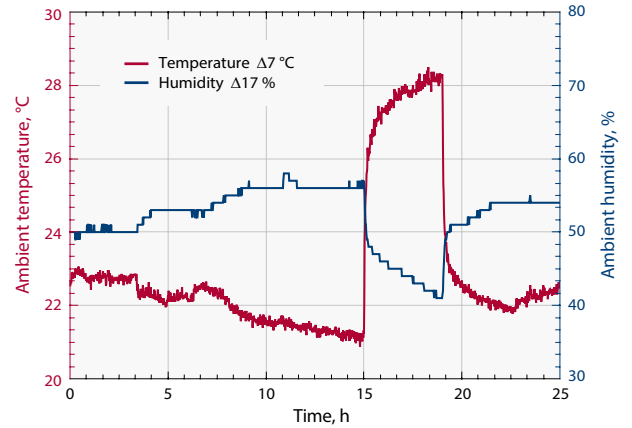

Harsh environment conditions (air-cooled version)

**WATER-COOLED CARBIDE WITH A SCIENTIFIC INTERFACE**

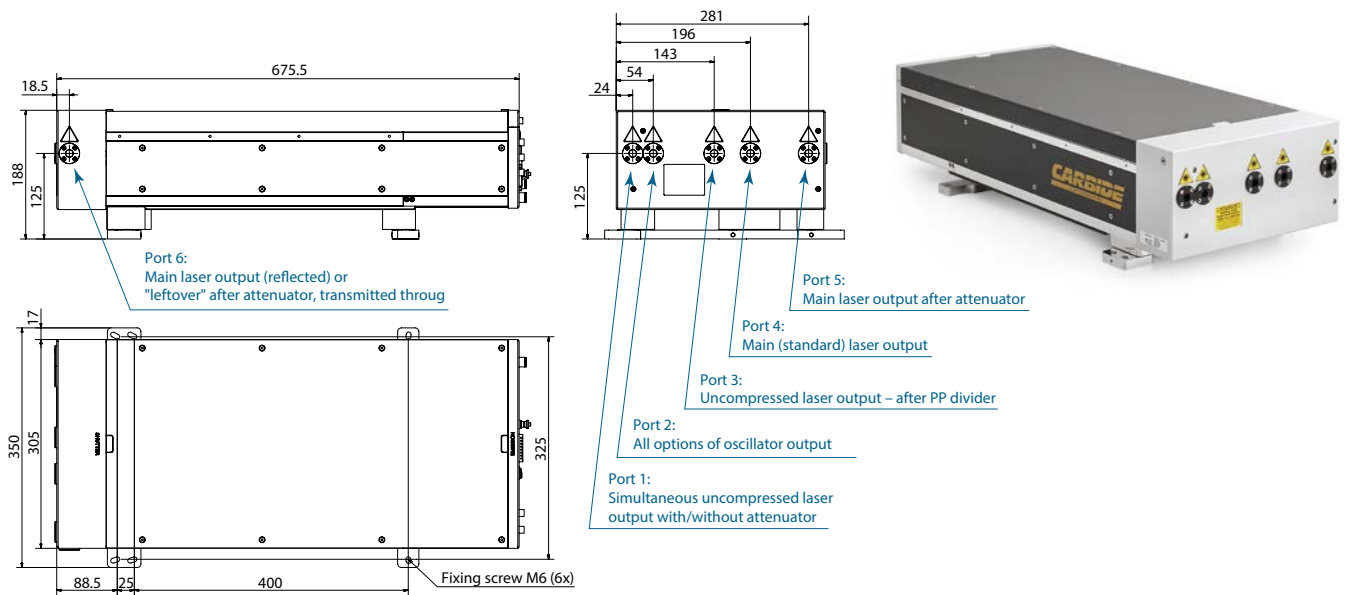

Drawings of CARBIDE with scientific interface

ULTRAFAST LASERS

OSCILLATORS

HARMONICS GENERATORS

OPTICAL PARAMETRIC AMPLIFIERS

SPECTROMETERS

AUTOCORRELATORS

# CARBIDE

## Automated Harmonics Generators



Air-cooled CARBIDE with harmonics generator module

### FEATURES

- 515 nm, 343 nm and 257 nm
- Output selection by software
- Mounted directly on a laser head and integrated into the system
- Rugged, industrial grade mechanical design

CARBIDE laser can be equipped with automated harmonics modules. Selection of fundamental (1030 nm), second (515 nm), third (343 nm) or fourth (257 nm) harmonics outputs

are available by software control. Harmonics generators are designed to be used in industrial applications where a single output wavelength is desired.

### SPECIFICATIONS

Product name	2H	2H-3H	2H-4H
Output wavelength (automated selection)	1030 nm 515 nm	1030 nm 515 nm 343 nm	1030 nm 515 nm 257 nm
Input pulse energy	20 – 400 $\mu$ J		
Pump pulse duration	< 300 fs		
Conversion efficiency	> 50 % (2H)	> 50 % (2H) > 25 % (3H)	> 50 % (2H) > 10% (4H) <sup>1)</sup>
Beam quality ( $M^2$ )	< 1.3 (2H), typical < 1.15	< 1.3 (2H), typical < 1.15 < 1.4 (3H), typical < 1.2	< 1.3 (2H), typical < 1.15 n/a (4H)

<sup>1)</sup> Maximum output power 1 W.

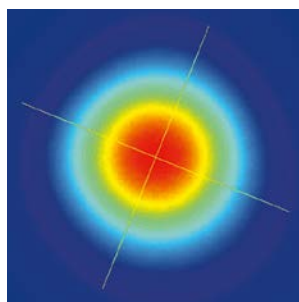
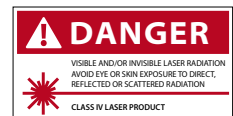

Typical CARBIDE 1H beam profile.  
60 kHz, 5W

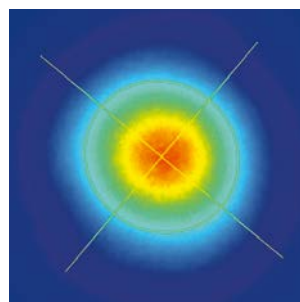

Typical CARBIDE 2H beam profile.  
100 kHz, 3.4 W

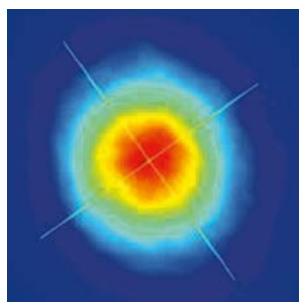

Typical CARBIDE 3H beam profile.  
100 kHz, 2.2 W

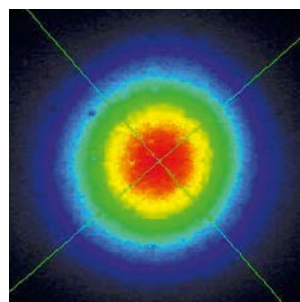

Typical CARBIDE 4H beam profile.  
100 kHz, 100 mW

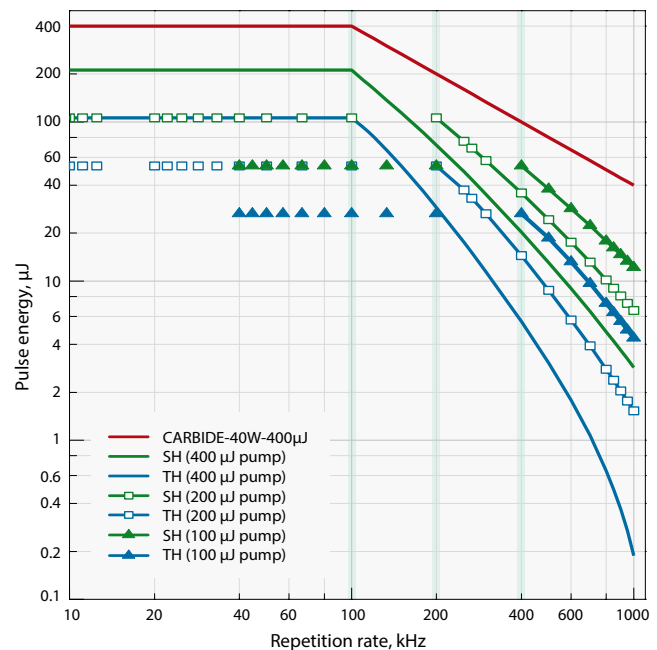

CARBIDE harmonics energy vs pulse repetition rate