

Optimized Solutions for Sensing and Measurement

CO₂ Sensor / O₂ Sensor / Agriculture Sensors / Data Logger



Optimized Solutions for Sensing and Measurement

SENSECUBE is a registered trademark of Industrial Sensor business of Korea Digital which established in 1997.

Based on 30 years of sensor expertise and manufacturing experience, SENSECUBE provides solutions for sensing and measurement which optimized for customer's needs.

History

1997

● 1997

*Established Korea Digital Co., Ltd
(Location : Seoul)*

● 1998

*Established a technology research institute
Developed boiler control system
Developed air conditioning (solar boiler, midnight
electricity) and cold and hot water control system
(Carrier Co., Ltd., Woongjin Coway Co., Ltd.)*

● 1999

*Developed air conditioner controller
(UTC Carrier)*

2000

● 2000

Developed a hot runner multi-temperature controller

● 2001

Developed MBL(Micro Computer Based Laboratory)

● 2002

Certified : ISO9001, ISO14000

● 2003

*Headquarters moved to Gurogu, Seoul
Developed a number of sensors for scientific experiments*

● 2004

*Established Industrial Sensor Business Department
Developed NDIR Dual Type CO₂ Sensor Module
(First Korean company to mass-produce and commercialize)*

- 2014
Developed a temperature and humidity sensor for agriculture
- 2015
Developed pH, EC positive fluid controller
Developed automatic weather equipment data logger
- 2016
Developed Zirconia O₂ sensor module
Developed a smart farm complex environment control system
Developed agricultural composite sensors
(temperature, humidity CO₂, O₂, ethylene, etc.)
- 2017
Developed data logging program (SR-100)
Developed RS485 to USB converter
- 2018
Developed FDR soil sensor
(soil temperature, moisture content, electrical conductivity)
- 2019
Developed zirconia O₂ sensor module (~25%, ~95%)

2005

- 2005
International Standards Award Winner (Korea Efficiency Association)
Developed and supplied CO₂ sensor module for indoor ventilation
(Samsung Electronics)
Developed CO₂ & Temperature. Controller for air conditioning

- 2009
Selected as a promising small and medium business

- 2010
Developed galvanic O₂ sensor module

- 2011
Meteorological Business Registered (Meteorological Equipment Business)
No. 2011109-01

- 2012
Designated Export Promising SME (Small and Medium Business Administration)
Three Million Dollar Export Top Award (49th Trade Day)

- 2013
Developed automatic weather observation AWS equipment.
Developed a weather sensor (temperature, humidity, solar radiation wind direction,
wind speed, rainfall, atmospheric pressure)

2014

2020

- 2020
Developed CO₂ for high temperature sterilization.
Developed oxygen monitors and controllers

- 2021
Developed portable CO₂ Measuring Instrument
Developed CO₂ controller

- 2022
Developed O₂ controller
Developed O₂ Measuring Instrument

SENSECUBE CO₂ SENSOR

NDIR CO₂ Sensor Principle

The NDIR method utilizes the phenomenon that asymmetric or multiatomic gas molecules selectively absorb the wavelength of light corresponding to their natural vibration energy.

For example, H₂O shows maximum absorption rate at 1.4μm and 1.9μm while SO₂ at 4.0μm, CO₂ at 4.3μm and NO at 5.3μm.

CO₂ gas concentration can be detected by converting the absorbed amount of 4.3μm wavelength light emitted from the infrared lamp in different gas concentration into electrical signal while it reaches the sensor.

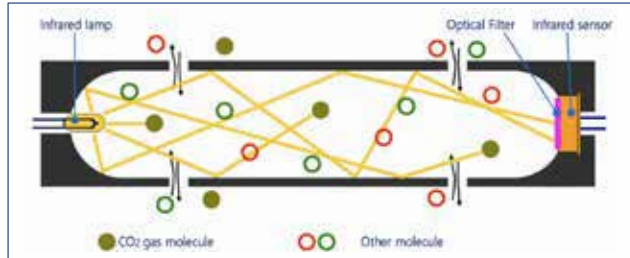

Difference between Dual Wavelength Type and Single Wavelength Type

Single Wavelength Type

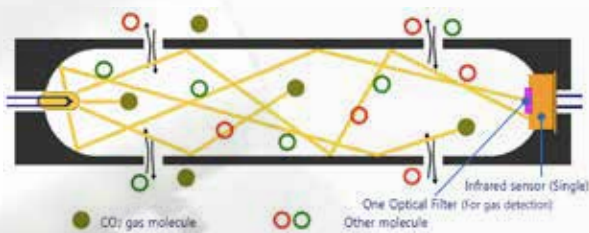

In general, it is called 'single type' in the market and most of low-price NDIR sensors on the market are single type.

However, single type needs frequent calibration due to the errors caused by deterioration with age or influence of external temperature which caused by long-term use of lamp, power supply, amplifier and etc.

It may not be suitable for indoor air control system depending on the installation environment if it is not used for calibratable instruments which use standard gas for measurement.

In most cases, those NDIR sensors which are not specified as dual type are single type.

Dual Wavelength Type

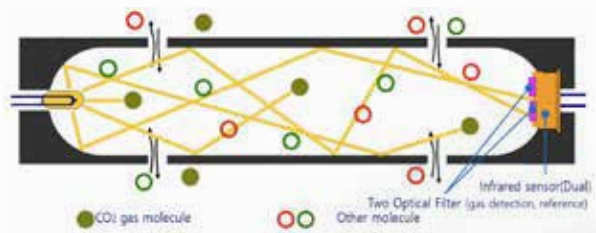

It is a type that compensates for the disadvantages of single type and is generally called 'dual type' in the market.

Dual type contains two sensors in a package. One of them detects the amount of infrared light which is influenced by carbon dioxide (CO₂) level while the other detects the "reference data"





"Reference data" is detected data of infrared light in the wavelength band which is not affected by CO₂ or other gases, and it acts as a self-calibration according to external influences.

It is the most stable type and can maintain long-term precision without any calibration and is also most commonly used for IAQ.

SENSECUBE' s CO₂ detection method is NDIR Dual Wavelength type.

Types and Characteristics of CO₂ Gas Sensors

This is a relative comparison of the CO₂ gas detection method currently in use.

Type	Principal	Very good		Good		Normal		X Not good	
		Sensitivity	Accuracy	Selectivity	Response	Life Time	Economic		
<p>Semiconductor type</p> 	<p>It is a method using the change of electrical conductivity according to the gas concentration.</p> <p>When the boundary of semiconductor constituent particles is exposed to clean air, the electrical conductivity becomes lower due to the formation of potential barrier by oxygen adsorption, but when contacted with reducing gas, the adsorbed oxygen combines with this gas, which lowers the potential barrier and increases the electrical conductivity.</p>			X					
<p>Solid electrolyte type</p> 	<p>Solid is generally classified into conductors, semiconductors, and insulators according to the magnitude of electrical conductivity, but those that exhibit conductivity as the ions move at high temperatures in the insulator are called ion conductors or solid electrolytes.</p> <p>This detection method measures the change of electromotive force detected in the electrolyte according to the gas concentration.</p>		X	X					
<p>Thermal conductivity type</p> 	<p>Depending on the material, the intrinsic constant that indicates the degree of heat transfer is called thermal conductivity. This detection method uses a characteristic in which the intrinsic thermal conductivity differs depending on the gas.</p>	X		X					
<p>Nondispersive Infrared absorption type (NDIR)</p> 	<p>This method uses the phenomenon that the gas molecules having an asymmetric structure or more than 3 atoms selectively absorb the energy corresponding to its own vibration energy have excellent selectivity, high precision, high reliability and long-term stability.</p> <p>NDIR CO₂ gas sensor module has been difficult to apply at reasonable price depending on imports, but the price has dropped to low level as our "Korea Digital Co., Ltd" is the first localization in Korea.</p>								△

There are various gas detection methods such as catalytic combustion, pyrolysis, and ion, but they are not suitable for measuring non-inert gas (CO₂ gas). So, It is excluded from the comparison.

The table above is a relative comparison of common characteristics

CO₂ Sensor Module

CO₂ Sensor module specification

Applicable model		KCD-AN300	KCD-HP100	KCD-HP200	KCD-HP300	KCD-HS100	KCD-HS300	KCD-HC	KCD-HF	Remark
Measurement range	0 ~ 2,000 ppm	<input type="radio"/>	<input type="radio"/>			<input type="radio"/>				
	0 ~ 3,000 ppm	<input type="radio"/>	<input type="radio"/>			<input type="radio"/>				
	0 ~ 5,000 ppm	<input type="radio"/>	<input type="radio"/>			<input type="radio"/>				
	0 ~ 8,000 ppm	<input type="radio"/>	<input type="radio"/>			<input type="radio"/>				
	0 ~ 10,000 ppm	<input type="radio"/>	<input type="radio"/>			<input type="radio"/>				
	0 ~ 2%		<input type="radio"/>	<input type="radio"/>		<input type="radio"/>		<input type="radio"/>	<input type="radio"/>	
	0 ~ 5%			<input type="radio"/>			<input type="radio"/>	<input type="radio"/>	<input type="radio"/>	
	0 ~ 10%			<input type="radio"/>			<input type="radio"/>	<input type="radio"/>	<input type="radio"/>	
	0 ~ 20%				<input type="radio"/>		<input type="radio"/>	<input type="radio"/>	<input type="radio"/>	
Analog output	0 ~ 4VDC	<input type="radio"/>	<input type="radio"/>	<input type="radio"/>	<input type="radio"/>	<input type="radio"/>	<input type="radio"/>	<input type="radio"/>	<input type="radio"/>	
	0 ~ 5VDC	<input type="radio"/>	<input type="radio"/>	<input type="radio"/>	<input type="radio"/>	<input type="radio"/>	<input type="radio"/>			
	0 ~ 10VDC	<input type="radio"/>	<input type="radio"/>	<input type="radio"/>	<input type="radio"/>	<input type="radio"/>	<input type="radio"/>			
	4 ~ 20mA	<input type="radio"/>	<input type="radio"/>	<input type="radio"/>	<input type="radio"/>	<input type="radio"/>	<input type="radio"/>			
Digital output	UART	<input type="radio"/>								
	PWM									
	RS-485		<input type="radio"/>	<input type="radio"/>	<input type="radio"/>	<input type="radio"/>	<input type="radio"/>	<input type="radio"/>	<input type="radio"/>	
Power supply	8 ~ 12VDC							<input type="radio"/>	<input type="radio"/>	
	14 ~ 24VDC	<input type="radio"/>	<input type="radio"/>	<input type="radio"/>	<input type="radio"/>	<input type="radio"/>	<input type="radio"/>			
	24VAC/DC									
Others	Circuit enclosure	<input type="radio"/>	<input type="radio"/>	<input type="radio"/>	<input type="radio"/>	<input type="radio"/>	<input type="radio"/>	<input type="radio"/>	<input type="radio"/>	
	Gas filter enclosure	<input type="radio"/>	<input type="radio"/>	<input type="radio"/>	<input type="radio"/>	<input type="radio"/>	<input type="radio"/>	<input type="radio"/>		
	Diffusion Type	<input type="radio"/>	<input type="radio"/>	<input type="radio"/>	<input type="radio"/>	<input type="radio"/>	<input type="radio"/>	<input type="radio"/>		
	Flow-through Type		<input type="radio"/>	<input type="radio"/>	<input type="radio"/>	<input type="radio"/>	<input type="radio"/>		<input type="radio"/>	

1) The output signal and the measurement range are optional standards.

2) To meet some specifications, accessories sold separately are required.

3) Please contact us for unspecified standards.

4) Output voltage maybe limited depending on the power used.

5) Power specification : It may vary depending on environment.



KCD-HP100

Measurement

Measurement range	0~1%(2000ppm, 3000ppm, 5000ppm)
Accuracy*	±(3%FS+2%Reading)
Response Time	Within 1 minute(τ)
Signal update	every 0.75second

General

Initial start-up time Storage temperature	Within 1 minute -40~70
---	---------------------------

Operating conditions

Operating temperature	5~45
Operating humidity	0~95%RH(Non-condensing)

Electrical

Power supply	12~28VDC
Current consumption	average 70mA
Output signal	Choose from 0~5VDC, 0~10VDC, 4~20mA
Communication	RS-485 (Modbus RTU)

Operating conditions

Main Body	Φ43mm × 160mm
Cable	approx 1m Option 3m
Weight	below 350g

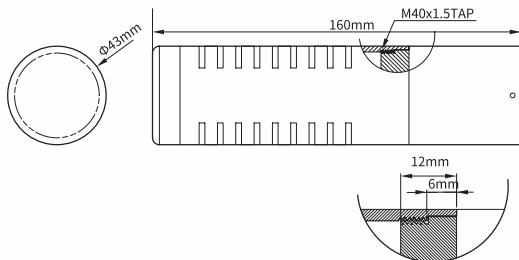

* Medium value of detection range with equipment conditions of the manufacturing plant @25

* The measurement range is adjusted in units of 1000 ppm

* When using the output signal 0-10V, the power supply is recommended to be 16VDC or higher.

Calibration may be necessary in a one-year period when using the normal environment

The above images and specifications are subject to change without notice for performance and quality improvement.



KCD-HP200, 300

Measurement

Measurement range	0~10%, 0~20%
Accuracy*	±(3%FS+2%Reading)
Response Time	Within 1 minute(τ)
Signal update	every 0.75second

General

Initial start-up time Storage temperature	Within 1 minute -40~70
---	---------------------------

Operating conditions

Operating temperature	5~45
Operating humidity	0~95%RH(Non-condensing)

Electrical

Power supply	12~28VDC
Current consumption	average 70mA
Output signal	Choose from 0~5VDC, 0~10VDC, 4~20mA
Communication	RS-485 (Modbus RTU)

Operating conditions

Main Body	Φ43mm × 94mm
Cable	approx 1m Option 3m
Weight	below 250g

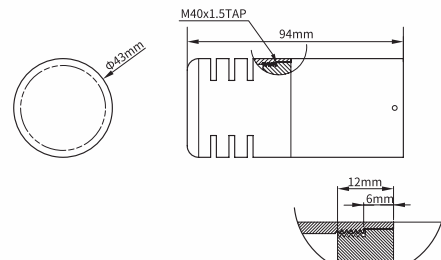

* Medium value of detection range with equipment conditions of the manufacturing plant @25

* The measurement range is adjusted in units of 1000 ppm

* When using the output signal 0-10V, the power supply is recommended to be 16VDC or higher.

Calibration may be necessary in a one-year period when using the normal environment

The above images and specifications are subject to change without notice for performance and quality improvement.

CO₂ Sensor Module



KCD-HS 100, 300

Measurement

Measurement range	HS100 : 2000ppm, 3,000ppm, 5,000ppm, 1%
Accuracy*	HS300 : 2%, 5%, 10%, 20% ±(3% F.S.+2%Reading)
Response Time	Within 65 seconds
Signal update	every 0.75second

Operating conditions

Operating temperature	5~45
Operating humidity	0~95%RH(Non-condensing)
Storage temperature	-40 ~ 70

Electrical

Power supply	12~24VDC
Poewer consumption	average 70mA
Analog Output	4~20mA
Communication	RS-485(Modbus RTU)

• Outside view

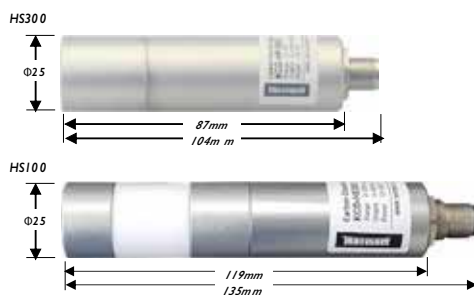

• Connector

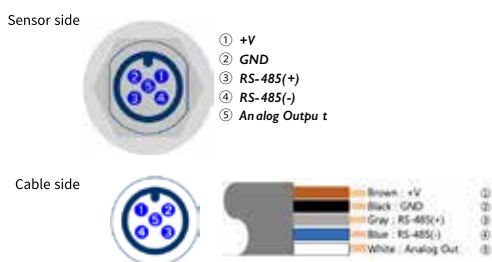

KCD-HS800

Measurement

Measurement range	0.1~20 Vol.%
Accuracy*	±(3% F.S.+2%Reading)
Response Time	Within 65 seconds
Signal update	every 0.75second

Operating conditions

Operating temperature	5~45
Operating humidity	0~95%RH(Non-condensing)
Storage temperature	-20 ~ 70
Sensor high temperature limits	150 (only sensor, No CO ₂ Measurement)

Electrical

Power supply	12~24VDC
Poewer consumption	average 70mA
Analog Output	4~20mA
Communication	RS-485(Modbus RTU)

• Outside view

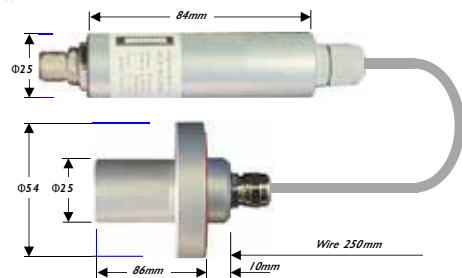

• Connector



• Dimensions

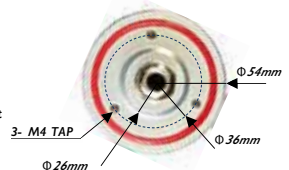

The above images and specifications have possibility to be changed without notice for performance and quality improvement.



KCD-DA100

Measurement

Measurement range	CO ₂	0~2,000/5000/10,000ppm
	Temperature	0~60 ,
	Humidity	0~99% RH (option)
Accuracy	CO ₂	±(4%FS+3%Reading)
	Temperature	±2 ,
	Humidity	±3 % (option)
Response Time (t63)	CO ₂	within 30 seconds
	Temperature	within 10 seconds (option)
	Humidity	
Signal update		every 1.5 seconds
Interface		LCD, 3 button switch

General

Initial start-up time	CO ₂	within 3 minutes
	Temperature, Humidity	within 30 seconds (option)
Storage temperature		-20 ~ 80
Operating environment		5 ~45 (CO ₂)

Electrical

Power supply		24 V AC/DC ±10%
Current consumption		average 70mA
Output signal	CO ₂	0~10VDC or 4~20mA, RS-485
	Temperature	Relay SPST
	Humidity	0~10VDC or 4~20mA

Dimensions

82mm × 124 mm × 29 mm
below 150g

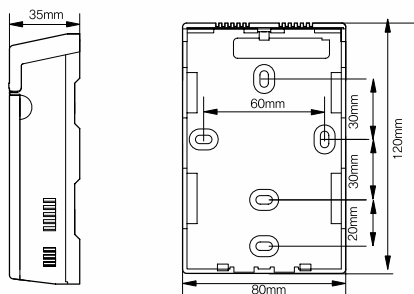

The temperature and humidity functions of KCD-DA model are optional.



KCD-AN300

Measurement

Measurement range	0~2000ppm, 0~3000ppm, ~5000ppm, ~10000ppm
Accuracy*	±(4%FS+3%Reading)
Response Time	Within 40 seconds(τ)
Signal update	1.5 seconds

General

Initial start-up time	within 1 minute
Storage temperature	-40~70

Operating conditions

Operating temperature	0~50
Operating humidity	0~95%RH(Non-condensing)

Electrical

Power supply	12~24VDC
Current consumption	average 70mA
Output signal	choose form
	4~20mA, 0~10VDC, 0~5VDC
Communication	UART(38,400bps)

Operating conditions

L x W x H	93mm × 53mm × 28mm (w/CASE)
Screw interval	84mm±0.2mm(Φ3.5mm)
Weight	below 30g

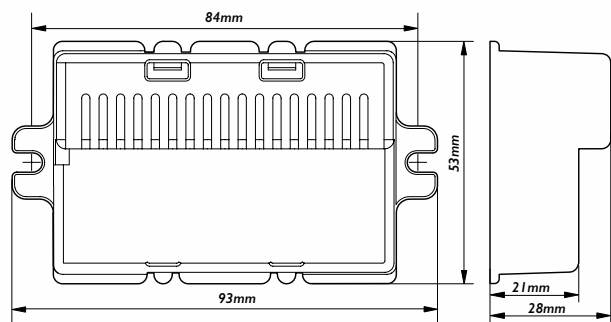

* Medium value of detection range with equipment conditions of the manufacturing plant @25

* The measurement range is adjusted in units of 1000 ppm
The above images and specifications are subject to change without notice for performance and quality improvement.

CO₂ Sensor Module



KCD-HC (Diffusion aspirated type)

Measurement

Measurement range	5%, 10%, 20%
Accuracy*	±(3%FS+2%Reading)
Response Time	within 1 minute(τ63)
Signal update	every 0.75 second

General

Initial start-up time	within 1 minute
Storage temperature	-40~70

Operating conditions

Operating temperature	5~45
Operating humidity	0~95%RH(Non-condensing)

Electrical

Power supply	8~15VDC
Output signal	0~4VDC
Communication	RS-485 (Modbus RTU)
Current consumption	average 70mA

Dimensions

Weight	below 70g
--------	-----------

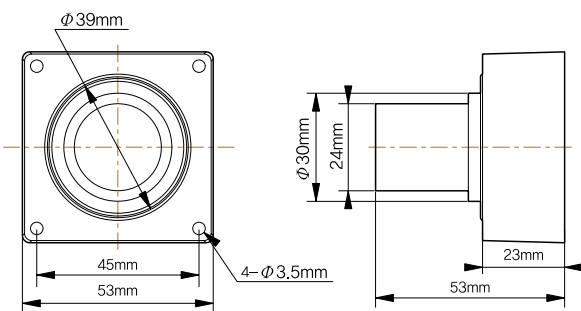

* Medium value of detection range with equipment conditions of the manufacturing plant @25
 Calibration may be necessary in a one-year period when using the normal environment.
 The above images and specifications are subject to change without notice for performance and quality improvement.



KCD-HF (Flow through type)

Measurement

Measurement range	5%, 10%, 20%
Accuracy*	±(3%FS+2%Reading)
Response Time	within 10 seconds (τ63)
Signal update	every 0.75 second

General

Initial start-up time	within 1 minute
Storage temperature	-40~70

Operating conditions

Operating temperature	5~45
Operating humidity	0~95%RH(Non-condensing)

Electrical

Power supply	8~15VDC
Output signal	0~4VDC
Communication	RS-485 (Modbus RTU)
Current consumption	average 70mA

Dimensions

Weight	below 70g
--------	-----------

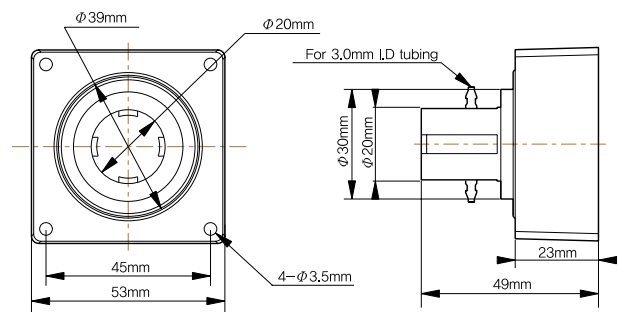

* Medium value of detection range with equipment conditions of the manufacturing plant @25
 Calibration may be necessary in a one-year period when using the normal environment.
 The above images and specifications are subject to change without notice for performance and quality improvement.

O₂ Sensor Module

Comparing detection method of O₂ gas sensor

A gas sensor is a device that quantifies a specific component gas contained in a gas by a suitable electrical signal. About 50 years ago, since the introduction of gas sensors using oxide semiconductors such as ZnO and SnO₂ for the first time, it has been the first result of the gas sensors to be put into practical use as gas leak detectors for LP gas and city gas through research and development.

After that, a solid electrolyte oxygen sensor for automobile air-fuel ratio control and metal smelting appeared. Also it was put to practical use in medical and air conditioning equipment.

Type	Principal	feature
Titanium type (Semiconductor type)	<p>This sensor uses the change in resistance of an electron donor of a gas to be detected adsorbed on the surface of an oxide semiconductor or a resistance of a semiconductor element depending on electron acceptability and the element material is titania (TiO₂ titanium dioxide).</p> <p>Titania is an n-type semiconductor device. When a constant voltage is applied to a titania element using a characteristic that the resistance becomes small when the amount of oxygen around the titania is high and the resistance becomes large when the amount of oxygen is small, the resistance value and the voltage changes while changing.</p>	<p>Small and lightweight.</p> <p>The sensitivity is relatively high. The life span of the sensor is long. (5 to 6 years) Selectivity to gas is poor.</p> <p>Temperature dependency is high, requiring temperature compensation It operates at high temperatures above 300 .</p>
Galvanic type (Electrochemical)	<p>It is made by noble metal (silver or gold) as the anode and a non—metal (lead) as the cathode and precipitating it in the electrolytic solution (caustic soda water).The gas concentration is detected by the reduction current generated in proportion to the oxygen dissolved in the electrolyte solution by the oxygen in the gas</p>	<p>Can be measured at room temperature.</p> <p>The linearity of the output signal is good.</p> <p>Temperature and humidity are critical.</p> <p>Life is short. (1 year)</p>
Zirconia type (Solid Electrolyte Gas Sensor)	<p>The solid electrolyte that reacts using a solid electrolyte can be used to detect the electromotive force of the cell or the concentration of the current gas.</p> <p>[Concentration cell type] A method of forming a platinum electrode on both sides of zirconium oxide and detecting the electromotive force (voltage) caused by the difference in concentration on both sides.</p> <p>[Limit Current Type oxygen sensor] Oxygen ion conductivity of zirconium oxide is used, and there is no need for troubles such as standard gas and frequent calibration.</p>	<p>Small and lightweight. The life span of the sensor is long. (5 to 6 years) There is no need for separate calibration procedures during use.</p> <p>It operates at high temperatures above 300 .</p> <p>The price is higher than the electrical formula.</p>
Optical system	<p>In the case of the optical system, a specially designed optical layer is used instead of an oxygen permeable diaphragm, and the reaction characteristic of the light irradiated on the optical layer is used. In the optical layer, when the light of a specific wavelength is irradiated, (Fluorescence quenching time) is inversely proportional to the amount of oxygen in the medium.</p>	<p>Maintenance is convenient.</p> <p>Can be used at room temperature.</p> <p>The life span is longer than the electrolytic type. (2 to 3 years)</p> <p>Initial stabilization time is short. (Within 1 minute)</p> <p>It is expensive compared to chemical formula or electrolytic type.</p>

There are various other methods of gas detection, but this comparison is briefly compared with a relatively well known method of detecting oxygen gas.

From the SENSECUBE models, ON-100 is "galvanic" and ON-300 is "zirconia limiting current method".

O₂ Sensor Module



KCD-ON200 (Zirconia)

• Features

- Zirconium Dioxide (ZrO₂ Measuring element)
- Reliable long-term use
- Various output signals
- Analog Output: 4-20mA , 0 - 5VDC
- Communication: RS 485(Modbus RTU)
- 2 open collector contacts for remote control
- High precision, high accuracy
- high linear output signal
- Easy calibration
- Easy installation (small and light)

• Application

- Accident prevention occurred by lack of oxygen
- Accident prevention in enclosed area
- Combustion control System
- Monitor air quality in workshop, laboratory
- Gas mixing control system (Steel Mill)
- Oxygen generating control System
- Medical LAB equipment (cell culture equipment)
- Crop storage, transport equipment
- Detect fermentation and corruption

• Caution

The oxygen concentration in the atmosphere is known to be about 20.9% (20.946%) but this is a dry atmosphere. However, the calibration using the atmospheric reference button is set to 20.7% considering the surrounding environment and humidity conditions. Any value can be set by communication using calibration gas. Please check the communication protocol to check the settings

Measurement

Measurement	Measurement range	0.1(1) ~ 25.0% O ₂
	Measuring method	Zirconia (ZrO ₂ Limit Current Type)
	Error range after calibration	<±1 %
	Repeatability	±1 % of measured value
General	Operating Temperature	-20 ~ 70
	Operating Humidity	98%RH, (Non-condensing)
	Permissible gas temperature	-10 to +50
	Preheating time	2 minutes
Interface	Display	Concentration display : FND 3 Digit Control Output (1) LED (if open collector on) Control Output (2) LED (if open collector on)
	Controller	Rotary Encoder Switch
Electrical	Power Supply	12~24 VDC
	Power Consumption	Below 3W
	Analog Output	4~20mA, 0 ~ 5VDC
	Communication Type	RS-485 (Modbus RTU)
	Open Collector Output	Output Control (1) ,Controle(2) : below 100mA, DC24V
Dimensions	Dimensions	68mm x 100mm x height 40 mm Distance between holes : 112 mm
	Weight	165 g

- (1) Long exposure to oxygen concentrations below 0.1% can affect the measuring elements.
- (2) Calibrate under stable atmospheric pressure conditions.
- (3) The sensor measures oxygen concentration by measuring the partial pressure of oxygen in the module. Therefore, there may be variations depending on the air pressure being calibrated. It can be used through calibration at atmospheric pressure in the environment of use.
- (4) Calibration to specific concentrations is possible.

• Dimensions

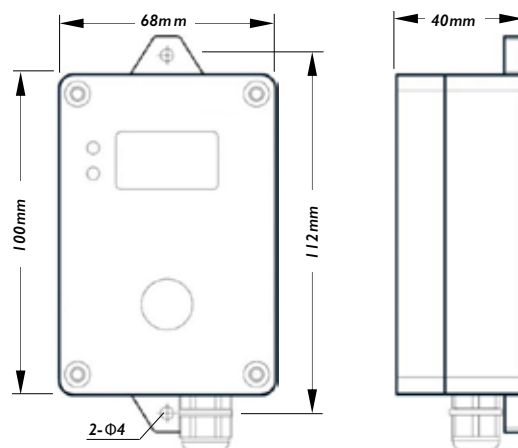

The above images and specifications are subject to change without notice for performance and quality improvement.



KCD-ON100 (Galvanic Oxygen Sensor)

Measurement

Sensor Type	Electrochemical (Galvanic type)
Measurement Range	0.1 ~ 99.9 Vol.%O ₂
Accuracy	±(0.5vol.% +2% Reading)

General

Preheating time	1 minute
Gas flow	0 ~ 10m/s
Operating Environment	0 ~ 45 °C, 0~95%RH (Non-condensing)
Storage temperature	-20~60

Electrical

Power supply	24V AC/DC (Option: 12VDC)
Power consumption	approx 25mA
Analog Output	0~10 VDC, 4~20mA

Dimensions

Board	90mm x 70mm (Only Board)
-------	--------------------------

* Cell (M-04) is a consumable item and sold separately.

M-04 (Oxygen Galvanic Cell)

Measurement

Measurement range	0 to 100 Vol.%
Response time	Within 10 seconds

General

Electrical connector	3-pin Molex gold plated
Nominal sensor Life	above 1,000,000 Vol.% h
Operating temperature	0 to 40

Electrical

Output signal	13 to 16.5 mV @dry ambient air
Zero offset voltage	below 0.2 mV in 100% N ₂ , applied for 5 min

KAU characteristics are based on conditions at 25°C, 50% RH and 1013 hPa.
The output signal decreases with time of use.

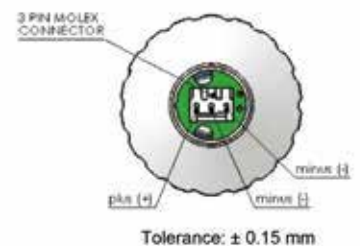
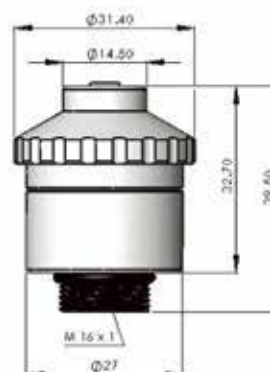
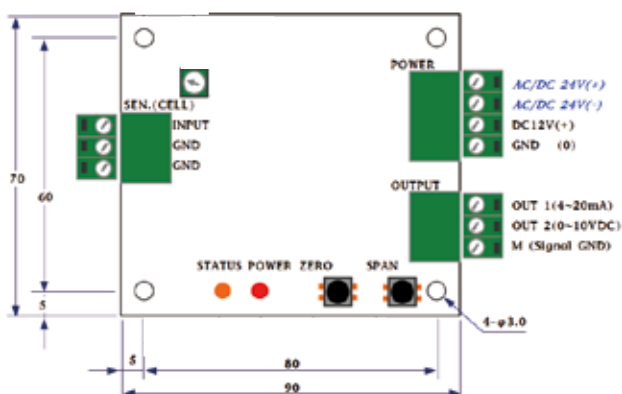

O₂ Sensor Module



KCD-ON310 (Zirconia)

Measurement

Sensor Type	Solid electrolytes (Zirconia)
Measurement Range	0.1 (1) ~ 25.0 Vol.% O ₂ , (Option 0.1~95Vol.%)
Accuracy	< ±1 % F.S.
Repeatability	±1 % of measured value

General

Measurement Environment	-20~70 , 95%RH (non condensing)
Permissible gas temperature	-10 to +50
Heater Warm up time	About 3 minute
Calibration Button	Default (Factory calibration), Span (20.7%)

Electrical

Power supply	12~ 24 VDC
Current consumption	below 200mA
Output	4~20mA, 0~5Vdc (or 0~10VDC)
Communication	RS-485 (Modbus RTU)

Dimensions

Body	53mm x 53mm
Weight	60g

(1) Prolonged operation below 0.1% O₂ can damage the sensing element.

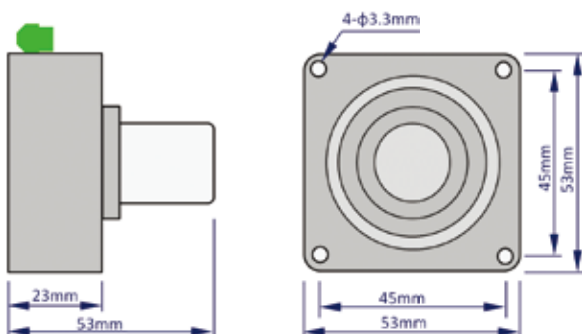

The above images and specifications are subject to change without notice for performance and quality improvement.

KCD-ON320 (Zirconia)

Measurement

Sensor Type	Solid electrolytes (Zirconia)
Measurement Range	0.1 ~25.0 Vol.%, (Option 0.1~95 Vol.%)
Accuracy	below ±1 % FS
Repeatability	±1 % of measured value

General

Measurement Environment	-20~70 , 95%RH (non condensing)
Permissible gas temperature	-10 to +50
Heater Warm up time	About 3 minute
Calibration Button	Default (Factory calibration), Span (20.7%)

Electrical

Power supply	12~ 24 VDC
Current consumption	below 200mA
Output	4~20mA, 0~10Vdc (or 0~5VDC)
Communication	RS-485 (Modbus RTU)

Dimensions

Board	90mm x 70mm (Only Board)
-------	--------------------------

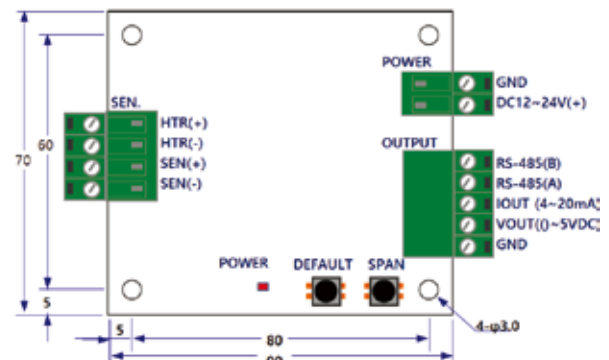

Agriculture Sensors



PE300 (pH, EC Controller)

Measurement

Measurement Range	pH 0.0 ~ 14.0, EC 0 ~ 5dS/m
Accuracy	pH ± 0.05 (@ pH3 ~ pH8) EC $\pm 2\%$ F.S. (@ 0 ~ 4dS/m)
Temperature compensation	Temperature compensation factor applied
Display	128x 64 Wide Graphic LCD
Control	4 button switch

General

Storage temperature	-20 ~ 80
Operating environment	0 ~ 50, ~95%RH(Non-condensing)

Electrical

Power supply	24 VDC $\pm 10\%$
Current consumption	100mA (@24V)
Analog Output	4~20mA
Communication	RS-485 (Modbus RTU)
Output contact	Relay 2 (SPST)
Electrode manual calibration	pH Offset (pH7), Span (pH4 or pH10) EC Offset, Span

Dimensions

Board	180mm x 130 mm x H36mm
Mounting dimension	162mm x 112mm $\Phi 4.0$ 4ea
Weight	300g (except electrode)

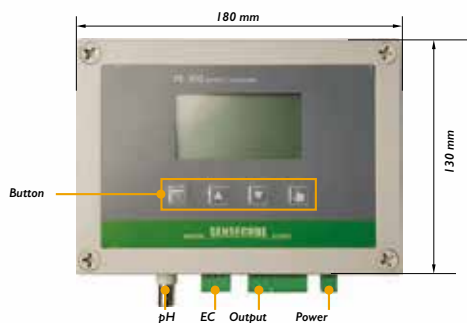

* Medium value of detection range with equipment conditions of the manufacturing plant @25 .

The above images and specifications are subject to change without notice for performance and quality improvement.

Temperature calibration is applied for EC control.

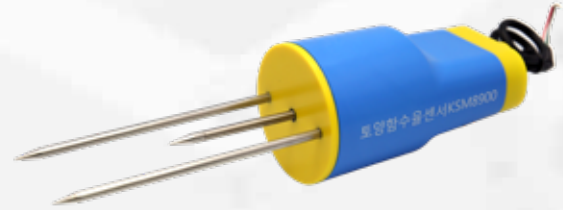

KSM8900 (Soil Sensor)

Measurement

Measurement range	Soil moisture content : 0 ~50%VWC Electrical conductivity : 0 ~ 10dS/m Soil temperature : -40 ~ 60 Soil moisture content : FDR
Measurement type	(Frequency Domain Reflectometry) Electrical conductivity : impedance Soil temperature : MEMS
Accuracy(@25)	Soil moisture content : C3%VWC (0 ~ 50%VWC) Electrical conductivity : ± 0.1 dS/m (@ 0 ~ 1dS/m) $\pm 10\%$ (@ 1 ~ 10dS/m) Soil temperature : ± 1
Degradation ability	Soil moisture content : 0.1%VWC Electrical conductivity : 0.01 dS/m Soil temperature : 0.1
Measurement cycle	MIN. 1 second

General

Initial start-up time	< 10 seconds
Operating temperature	-40 ~ 60
Operating humidity	below 95%RH

Electrical

Power supply	5VDC
Current consumption	70mA @5V
Communication	RS-485 (Modbus RTU)

Dimensions

External dimension	120mm x $\Phi 60$ mm (electrode length 110mm)
Weight	360g (include cable)
Cable length	3m

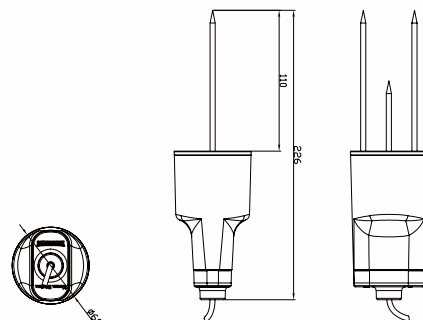

The above images and specifications are subject to change without notice for performance and quality improvement.

Agriculture Sensors



SWSR-7500 ^{+(plus)} (Pyrheliometer Sensor)

Measurement

Measurement range	0~2,000 W/m ²
Spectral range	400~1,000nm
Resolution	1 W/m ²
Accuracy	±5%

General

Storage temperature	-40~80
Operating Environment	-40 ~ 60 , Max 95%RH

Electrical

Power supply	5~24VDC
Current consumption	10mA
Communication	RS-485 (Modbus RTU) 4~20mA(option)

Dimensions

Out Dimension	Sensor 43mm x 48mm(Dia. x H) Bracket 270mm x 70mm x 60mm AL 3.0t Cable 3m
---------------	---

* Please contact us for I2C and analog output.

• Dimensions

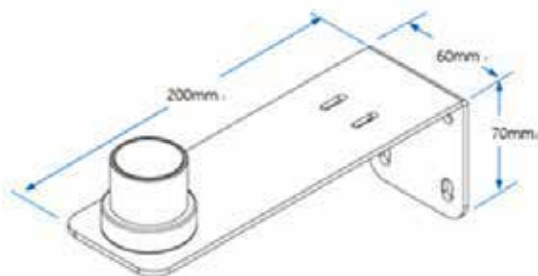

KST-7150 (Soil, water temperature sensor)

Measurement

Measurement type	Semiconductor type
Measurement range	-20 ~80
Accuracy	± 0.3

Electrical

Power supply	5~24VDC
Current consumption	< 0.5W
Communication	RS-485 (Modbus RTU) (Maximum speed : 115,200bps)

Dimensions

Dimensions	probe side Φ4mm x 120mm (SUS) converter side Φ17mm x 93mm (Plastic) cable : 4p 3m
Weight	100g (cable included)

• Appearance



• Connection



• Features

- Suitable for measuring the temperature of nutrient solution and root-zone.
- Semiconductor temperature sensor with excellent safety and durability against chemicals.
- Detection unit is made of stainless steel with strong corrosion resistance.
- Signal conversion unit is made of acetyl resin and high environmental resistance.
- IP67 class Waterproof rating.

The above images and specifications are subject to change without notice for performance and quality improvement.



KSB-7920 (Radiation Shield with Forced ventilation)

• Dimensions

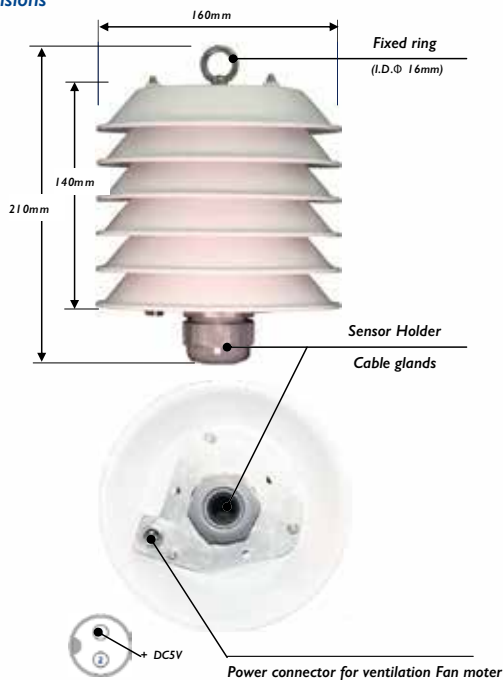

- **Features**
- Light PC+ABS shade structure.
- Faster and more accurate with forced ventilation.
- Ring structure, capable of easy installation in agriculture facility.
- Made of corrosion-resistant plastic and stainless steels.
- **General**
- Ventilation Type : Forced Ventilation (DC5V waterproof Fan motor)
- Power supply: DC 5V
- Current consumption : around 40mA
- Sensor O.D.: $\Phi 18 \sim \Phi 25\text{mm}$.
- Size : $\Phi 160 \times H210$
- Weight : 760g (sensor, cable excluded)

• Others

- Fan motor drive Power is not included
- Cable(connecting with sensor or fan motor / 4P, 3m) is sold separately



KSH-7310 (Temperature and humidity sensor)

Measurement

Measuring method	Humidity : Capacity method Temperature : Semiconductor
Measurement range	Humidity : ~ 99%RH Temperature : -40 ~ 60°C
Accuracy (@25)	Humidity : $\pm 3\%$ (10~90%RH) Temperature : ± 0.3 °C

General

Operating temperature	-40 ~ 70
Operating humidity	99%RH, non condensing

Electrical

Power supply	5 VDC
Current consumption	10mA (@5V)
Communication	RS-485 (Modbus RTU) Option : KSH7320 : SM-BUS

Dimensions

Sensor body	$\Phi 24\text{mm} \times 104\text{mm}$ (except cable)
Cable	M12-4P, 3m
Weight	140g (including cable)
Connector	M12-4p

• Dimensions

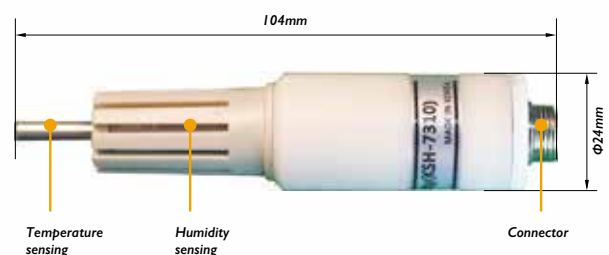

Portable Data Logger



KCD-TEMP U04

- TEMP U04 is a temperature data logger that stores 32,000 measurement data. Displays the current temperature, temperature notification status, number of memory stores, and battery status on the LCD.
- Connecting with USB port, log data can be converted to PDF and CSV format. PDF file includes temperature data (Max, Min, AVG, Time, etc.) and alarm information.

Measurement

Display units	or
Measurement Range	-30 ~ +60
Resolution	0.1
Accuracy	±0.5 (-20 ~ +40)
Memory Size	32,000
Recording Type	Press the button (or delayed start)
Measuring Cycle	10s ~ 18hours can be set (Default 10 minutes)
Delayed Start	0~254 minutes (Default 30 minutes)
Alarm setting	0~960 minutes (Default 10 minutes)
Alarm target	Set Upper, Lower value (Default <2 or >8)
Operating System	Windows 7, 8, 10
Report type	PDF, CSV file
Interface	USB 2.0
Battery	3V lithium battery(CR2032)
Life time of battery	about 1 year (Depending on the logging interval and environment)
Measure Condition	-30 ~ +60 , 0 ~ 95%RH (non-condensing)
Water proof Class	IP65
Dimensions	83 x 36 x 16mm
Weight	23g

• Application

- Control the transport temperature and storage temperature of food, medicines, and chemicals
- Freezer, refrigerator temperature control.
- Temperature control of fresh food
- Monitor Air conditioning.
- Temperature control of agriculture and horticulture
- Control temperature of buildings (house, ware house, museum, art gallery)



THD8 (Portable Temperature, Humidity Sensor)

- Light PC+ABS structure
- Faster and more accurate with forced ventilation
- Ring structure, capable of easy installation in agriculture facility
- Made of corrosion-resistant plastic and stainless steels

Measurement

Measurement range	Temperature : -20~80°C Humidity : 0~100%RH (Non-condensing)
Accuracy	Temperature : ±0.3°C (0~80°C) Humidity : ±2% (0~100%RH)
Measurement Cycle	1 sec~2 hour (Time can be set)

General

Alarm display	LCD Display
LCD display	4 digits, Temperature and humidity Iteration
Memory capacity	15,000 (Temperature & Humidity)
Export type	PDF(automatic), Excel(Software)

Software

Software	Configuration information, alarm history, temperature / humidity graph, temperature/humidity detail data
----------	--

Electrical

Power supply	1/2 AA Battery, 1200mAh
--------------	-------------------------

Dimensions

Size	124(L)×25(W)×12.5mm
weight	45g

Performance Graphs

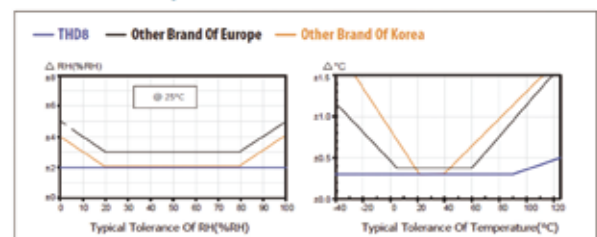

Measurement Controller



KCD-DA300 (Display / Controller)

• Feature

- Various sensors can be connected
- Support external RS-485(Modbus RTU)
- Support for 2 relays for output control
- Display current value
- Output Contact Point, During Settings
- Dot matrix graphics LCD

• Application

- Measurements and indicators
- Environmental control and alarm system
- Various sensors can be connected

• Applicable Sensors

- CO₂ sensor KCD-HPxx series
2,000ppm, 5,000ppm, 1%, 5%, 10%, 20%
- O₂ sensor KCD-ON-3xx series 25%, 100%
- Soil Sensor : KSM-8900
- Soil temperature, Soil water content, Soil EC
- Solar radiation Sensor
- Temperature and humidity sensor

Measurement

Measuring type	Applicable Sensor	CO ₂ Sensor and etc (Check Sensecube Product)
	Accuracy / repeatability	Check Sensor Specification Table
General	Storage temperature	-20 ~ 80
	Measure Environment	0 ~ 60 , Max 95%RH (non-condensing)
Interface	Display	DOT matrix graphics LCD
	Setting	4 button Switch
Electrical	Power supply	DC24V
	Current consumption	About 50mA (Sensor consumption current excluded)
	Communication	RS-485(Modbus RTU)
	Communication speed	38,400bps (2400 ~ 115,200bps Changeable)
	Communication cycle	1 sec
Dimension	Power supply	Selectable from DC5V, DC12V, DC24V (According to sensor)
	Size	86mm x 86 mm x H26mm (sensor excluded)
	Weight	About 150g (Sensor excluded)

• Dimensions

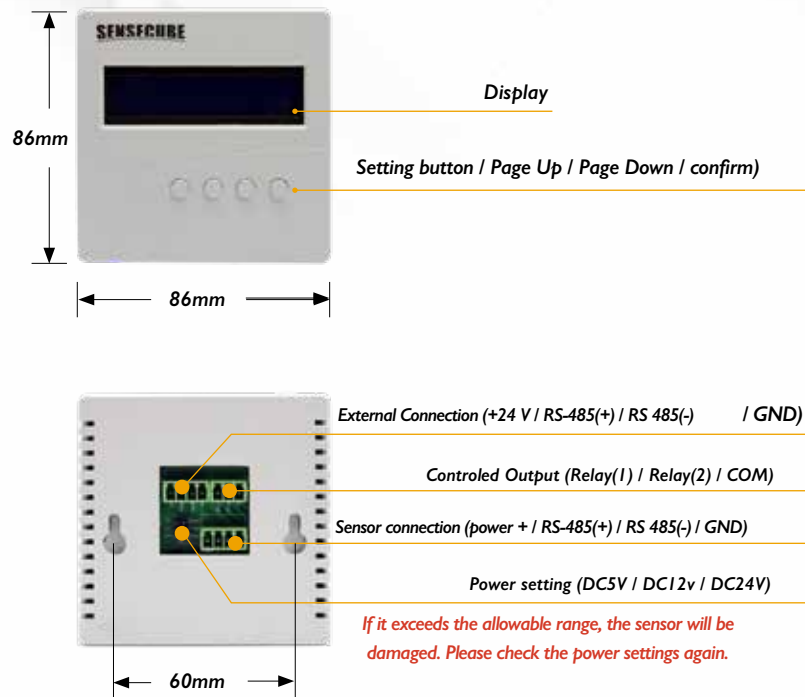

The above images and specifications are subject to change without notice for performance and quality improvement.

Measurement Controller



PL-100 (Measurement indicator)

• Feature

- Easy-to-use portable measurement indicator
- Two sensors can be measured at the same time
- Store up to 65,000 logging data (It may vary depending on the sensor type)
- Continuous use time after charging depends on the sensors
- Dot Matrix Graphics LCD
- Support English

• Application Model

- a portable measuring instrument
- Analysis of stored data

Measurement

Measuring type	Applicable Sensor	CO ₂ Sensor and etc (Check Sensecube Product)
	Channel	2 Channels (2 sensors can be connected at the same time)
	Data logging	65,536 point (It may vary depending on the connection sensor)
	Language	English
General	Storage Temperature	-20 ~ 80
	Measure Environment	0 ~ 50 , Max 95%RH (non-condensing)
Interface	Display	DOT matrix graphics LCD
	Setting	4 button Switch
Electrical	Power Supply	Lithium polymer battery (3.7V, 1,000mAh)
	Charging Type	USB (C- Type, DC5V)
	Sensor Power	DC5V, DC24V selectable (Selectable from the meter menu after connection, depending on the specifications of the connection sensor)
Dimensions	Size	91 mm x 178 mm x H42mm
	Weight	280g (Sensor excluded)

• Dimensions



The above images and specifications are subject to change without notice for performance and quality improvement.

Software

Sensor logging program and Converter

SR-100

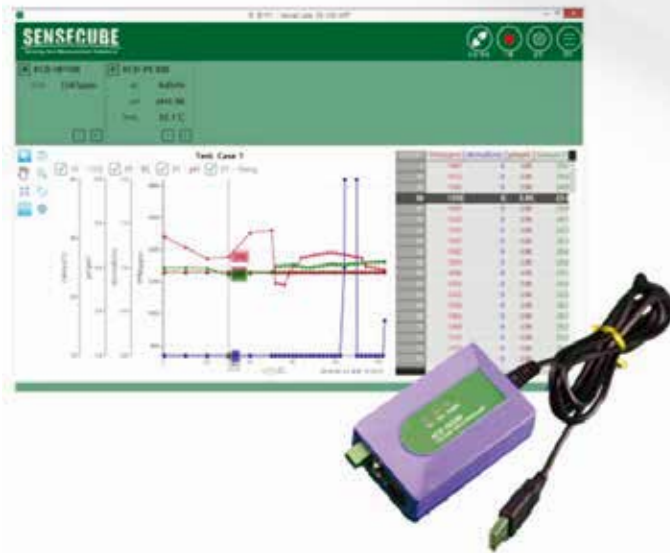

- Real-Time Data Collection & Time Series Analysis
- Supports Window 7/8 / 8.1 / 10, Korean and English
- Modbus Protocol RTU based
- Easy & Simple Setting Change (detection range, output signal, etc.)
- Encrypted Storage Method (Prevent data postmodification)
- Able to Mark on Graph
- Able to Save Screenshots
- Automatic Update to Latest Version when Online
- Able to Collect Data from 31 Sensors
- SENSECUBE Communication Converter Sold Separately
- Isolated USB to RS-485/UART (KCD-TK100)

• Application Model

- KCD-HP (CO₂ Sensor)
- KCD-HS (CO₂ Sensor)
- KCD-PE (nutrient solution controller)
- KCD-ON3xx (zirconia oxygen sensor)
- KSM8900 (soil sensor)
- KSH7310 (temperature and humidity sensor)
- SWSR-7500+(plus) (Solar radiation sensor)

* Depending on the firmware version of the HP series, older models may not be applied

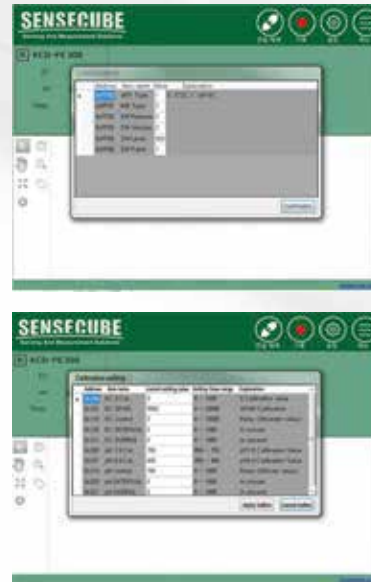

KCD-TK100 (USB to RS-485/UART Converter)





















- Baudrate : ~115,200bps
- RS-485 : 2 Wire
- UART : 3.3~5V TTL

Measurement

Communication Type	① RS 485 5V 2 Wire (RS485+, RS485-)	
	② UART Universal asynchronous receiver transmitter 3.3 ~5V TTL	
communication speed	Baudrate ~115,200bps	
Insulation voltage	2.5 kV	
Measure Environment	Temperature -20 ~ 70 Humidity 98%RH, (non-condensing)	
Dimensions	Size	Body 51 mm x 85mm x 30 mm Cable 1.5m
	Weight	about 100g

Accessories

Accessories & Maintenance goods

	Oxygen Galvanic cell	Applicable Model		Sensor CAL Adaptor(2)	Applicable Model
	<ul style="list-style-type: none"> • M-04 (Galvanic Cell) • Range 0.1~99.9 Vol% • Applicable Model : KCD-ON100 			<ul style="list-style-type: none"> • KCD-CL kit • Material : Aluminum • Applicable Model : KCD-HS series 	
	Sensor Bracket	Applicable Model		pH Electrode	Applicable Model
	<ul style="list-style-type: none"> • KCD-BR (01) • Material : Acetal, Stainless Steel • Applicable Model : KCD-HP series 			<ul style="list-style-type: none"> • PE300-10B • Applicable Model : KCD-PE300 	
	Sensor Bracket	Applicable Model		EC Electrode	Applicable Model
	<ul style="list-style-type: none"> • KCD-BR (02) • Material : Acetal, Stainless Steel • Applicable Model : KCD-HS series 			<ul style="list-style-type: none"> • PE300-10A • Applicable Model : KCD-PE300 	
	Sensor Bracket	Applicable Model		Electrode Holder	Applicable Model
	<ul style="list-style-type: none"> • KCD-BR (03) • Applicable Model : KCD-KSH7310 KCD-HS series 			<ul style="list-style-type: none"> • NPTF 3/4, NPTF 1/2 • Material : Polypropylens • Applicable Model : KCD-PE300 	
	Gas Sensor Filter	Applicable Model		Controller Bracket	Applicable Model
	<ul style="list-style-type: none"> • KCD-FL • Material : PTEF membrane • Applicable Model : KCD-HP series 			<ul style="list-style-type: none"> • KCD-BR(04) • Material : Aluminum • Applicable Model : KCD-DA300 	
	Sensor CAL Adaptor(1)	Applicable Model			
	<ul style="list-style-type: none"> • KCD-CL Kit • Material : Aluminum • Applicable Model : KCD-HP series 				



ISO-9001 (No.FM 590789)



ISO-14001 (No.EMS 590790)



100PPM(No.1-12-4-643)



NEP-MOCIE-2006-060

INNO-BIZ

INNO-BIZ(No.3012-0190)



KCD-AN
KCD-DA
KCD-HP
KCD-HS

RoHS



Scan the QR code to check the latest data of SenseCube.



Sensor Business Department Korea Digital Co., Ltd
#804, Ace Twin Tower2, 273 Digital-ro, Guro-gu, Seoul, south Korea
Tel. +82-2-2109-8838 email. sensor@koreadigital.com

www.sensecube.com

