

# FLINT

## Femtosecond Yb Oscillators



Typical view of FLINT model FL2

### FEATURES

- Sub-40 fs without any additional pulse compressor
- 250 nJ pulse energy
- 20 W output power
- 76 MHz is standard
- No amplified spontaneous emission
- Rugged, industrial grade mechanical design
- Automated harmonic generator (515 nm)
- Optional CEP stabilization
- Possibility to lock to external clock

The FLINT oscillator is based on Yb crystal pumped by high brightness laser diode module. Generation of femtosecond pulses is provided by Kerr lens mode-locking. Once started, mode-locking remains stable over a long period of time and

is immune to minor mechanical impact. Piezo-actuator can be implemented in customized oscillators in order to control the cavity length. FLINT oscillator can also be equipped with Carrier Envelope Phase (CEP) stabilization system.

### SPECIFICATIONS

Product name	FL1-02	FL1-08	FL2-12	FL2-20	FL1-SP
Max. average power	2 W	8 W	> 12 W	> 20 W	up to 2 W
Pulse duration (assuming Gaussian pulse shape)	< 100 fs	< 120 fs	< 120 fs	< 170 fs	30 ... 50 fs <sup>1)</sup>
Pulse energy	> 25 nJ	> 100 nJ	> 150 nJ	> 250 nJ	up to 25 nJ
Repetition rate	~ 76 MHz <sup>2)</sup>		~ 76 MHz		~ 76 MHz <sup>3)</sup>
Centre wavelength	1035 ± 10 nm				
Output pulse-to-pulse stability	< 0.5 % rms over 24 hours <sup>4)</sup>				
Polarization	Linear, horizontal				
Beam pointing stability	< 10 µrad/°C				
Beam quality	TEM <sub>00</sub> ; M <sup>2</sup> < 1.2				
Optional integrated 2H generator	Conversion efficiency > 30 % at 517 nm				

### PHYSICAL DIMENSIONS

Laser head	430 (L) × 195 (W) × 114 (H) mm	542 (L) × 322 (W) × 146 (H) mm	430 (L) × 195 (W) × 114 (H) mm
Laser head with 2H	442 (L) × 270 (W) × 114 (H) mm	542 (L) × 322 (W) × 146 (H) mm	
Power supply and chiller rack	642 (L) × 553 (W) × 540 (H) mm	642 (L) × 553 (W) × 673 (H) mm	642 (L) × 553 (W) × 540 (H) mm
Chiller	Included. Different options are available		

### UTILITY REQUIREMENTS

Electric	110 V AC, 50 – 60 Hz, 2 A or 220 V AC, 50 – 60 Hz, 1 A
Room temperature	15 – 30 °C (air conditioning recommended)
Relative humidity	< 80 % (non-condensing)

<sup>1)</sup> Depends on output power ~600 mW < 40 fs; up to 2 W < 50 fs.

<sup>2)</sup> Other repetition rates are available in the range from 60 to 100 MHz.

<sup>3)</sup> Other repetition rates are available in the range from 70 to 80 MHz.

<sup>4)</sup> With enabled power-lock, under stable environment.



### OPTIONAL EQUIPMENT

Harmonics generator HIRO	see p. 22
--------------------------	-----------

**LOCKING OF THE OPTICAL PULSE TO AN EXTERNAL SIGNAL**

PHAROS oscillator can be equipped with piezo actuators for precise control of the cavity length.

**LONG TERM HARMONIC LOCK STABILITY TEST (40 hours)**

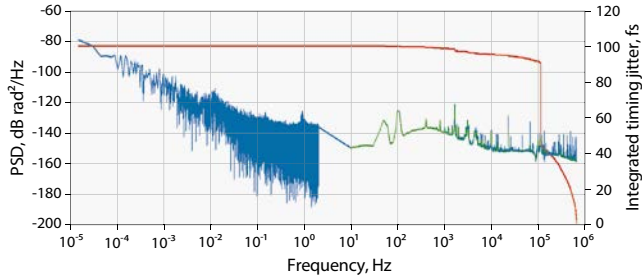

Laser oscillator (62.513 MHz) is locked to RF reference R&S SMB 100A (500.104 MHz). Measured integrated timing jitter\* at 0.01 mHz – 600 kHz bandwidth is 110 fs

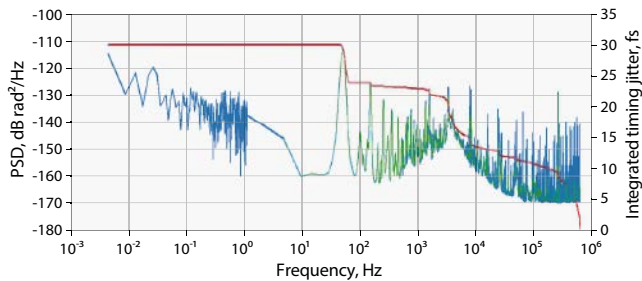

Laser oscillator (72.656 MHz) is locked to reference laser oscillator (72.656 MHz). Measured integrated timing jitter\* at 0.01 Hz – 600 kHz bandwidth is 30 fs

\* Integrated timing jitter up to 100 – 300 fs depending on RF source frequency, noise, environment conditions etc. For actual jitter specification please contact LIGHT CONVERSION.

**CARRIER ENVELOPE PHASE (CEP) STABILIZATION**

PHAROS oscillator can be equipped with nonlinear interferometer and feedback loop throughout the pump current of the laser diode bar for CEP stabilization.

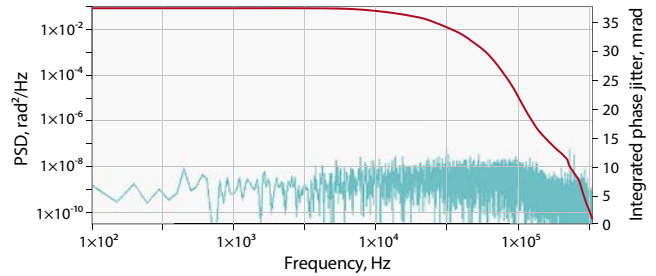

Single side power spectral density of  $f_{cep}$  phase noise (in loop) and the integrated phase jitter.

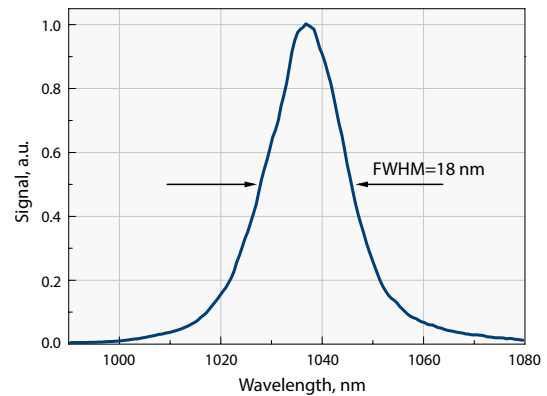

Typical FLINT optical spectrum

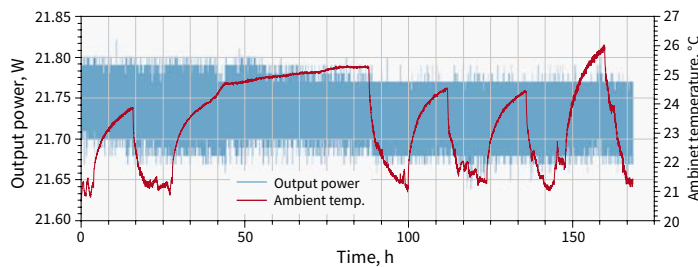

FLINT FL2-20 (20 W) output power stability under harsh environment conditions

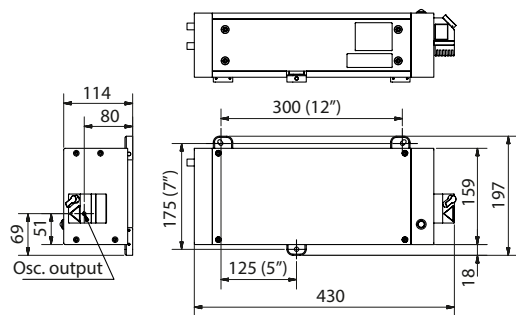

FLINT FL1 dimensions

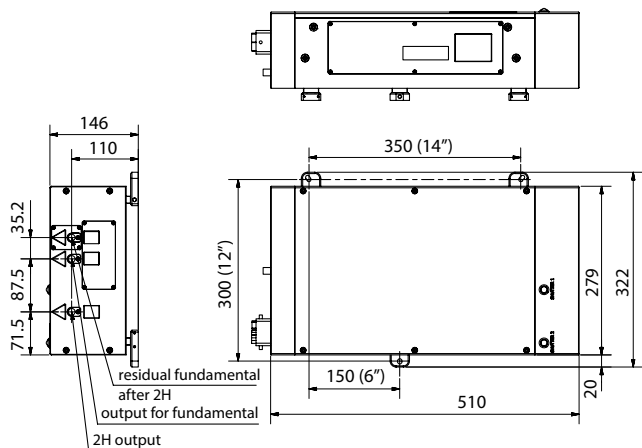

FLINT FL2 outline drawing

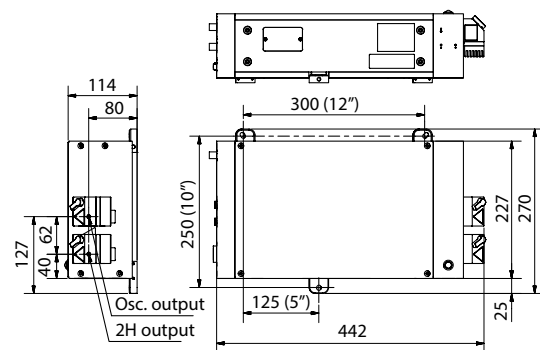

FLINT FL1 dimensions with second harmonic generator