

NLM Series Multi-mode Narrow Linewidth Laser



Key Features

- Linewidth < 0.1nm
- Excellent wavelength stability $\pm 7\text{pm}@4\text{h}$
- SMSR is better than 40dB (60dB optional)
- Built-in TEC, power stability $\pm 2\%$
- Contains PC control, emergency stop button, short circuit protection functions

Applications

- Raman spectroscopy
- Laser-induced fluorescence
- Pumping source

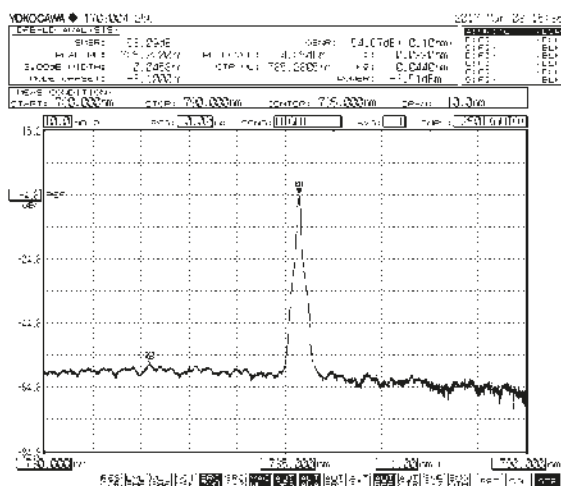

785nm laser spectrum (SMSR>40dB)

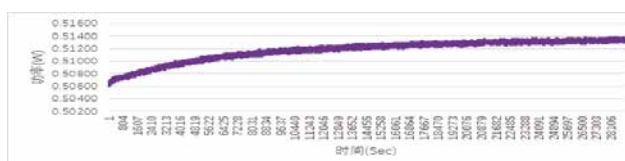

785nm power stability@4h

Technical Specifications

Optical Parameters						
Center Wavelength (nm)	638	785	808	830	976	1064
Output Power (mW)	500	500	600	600	800	800
Wavelength Tolerance (nm)	± 0.5					
Linewidth (nm)	<0.1	<0.1	<0.3	<0.1	<0.3	<0.1
Wavelength Stability	$\pm 7\text{pm}@4\text{h Typ.}$					
Power Stability	$\pm 2\%@4\text{h Typ.}$					
SMSR	30	35-45				
System Parameters						
Adjustability % Full Power	0~100%					
Warm up Time (min)	15					
Modulation Input	Analog signal 0~5V					
Control Interface	USB, BNC					
Connector	SMA905, FC/PC					
Output Fiber	105 μm , 0.22 NA					
Supply Voltage	+5VDC					
Power Consumption	<20W Typ.					
Storage Humidity	0~80% RH					
Storage Temperature (°C)	-10~60					
Operating Temperature (°C)	10~35					
Weight (kg)	1.2					
Dimensions (mm)	168×88×140					

Ordering Information

Wavelength (nm)	Output Power (mW)	Part Number	Connector
638	500	NLM-638-IF(F)-500	FC/PC
	500	NLM-638-IF(S)-500	SMA905
785	500	NLM-785-IF(F)-500	FC/PC
	500	NLM-785-IF(S)-500	SMA905
808	600	NLM-808-IF(F)-600	FC/PC
	600	NLM-808-IF(S)-600	SMA905
830	600	NLM-830-IF(F)-600	FC/PC
	600	NLM-830-IF(S)-600	SMA905
976	800	NLM-976-IF(F)-800	FC/PC
	800	NLM-976-IF(S)-800	SMA905
1064	800	NLM-1064-IF(F)-800	FC/PC
	800	NLM-1064-IF(S)-800	SMA905

Part Numbering Schema

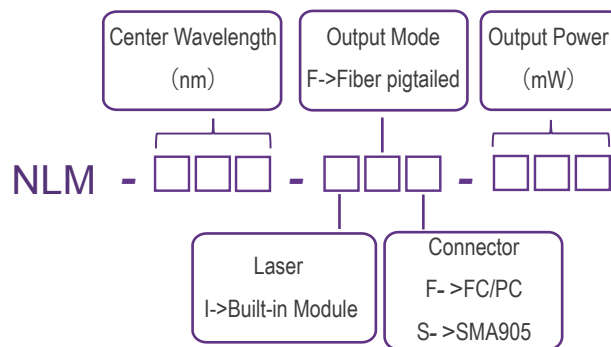

Mechanical Drawings (mm)

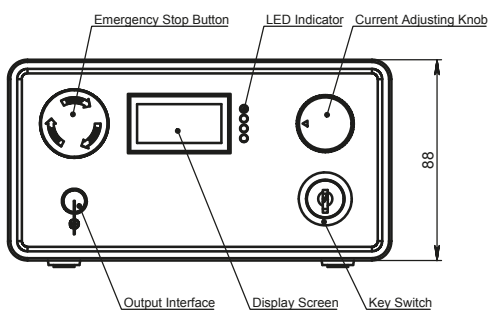

Front View

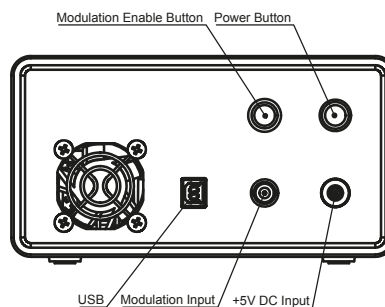

Back View

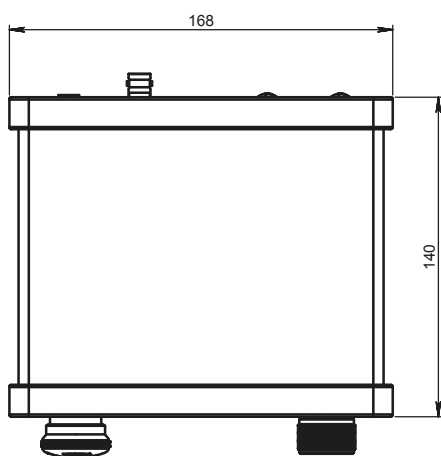

Top View

